

Art. 334-344 3 way zone ball valve "BY-PASS"

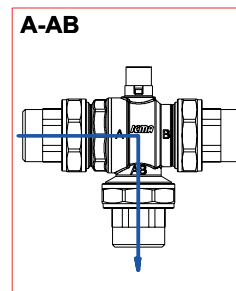
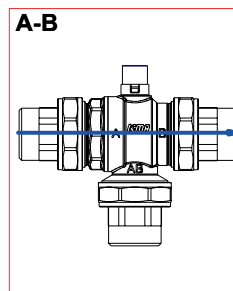
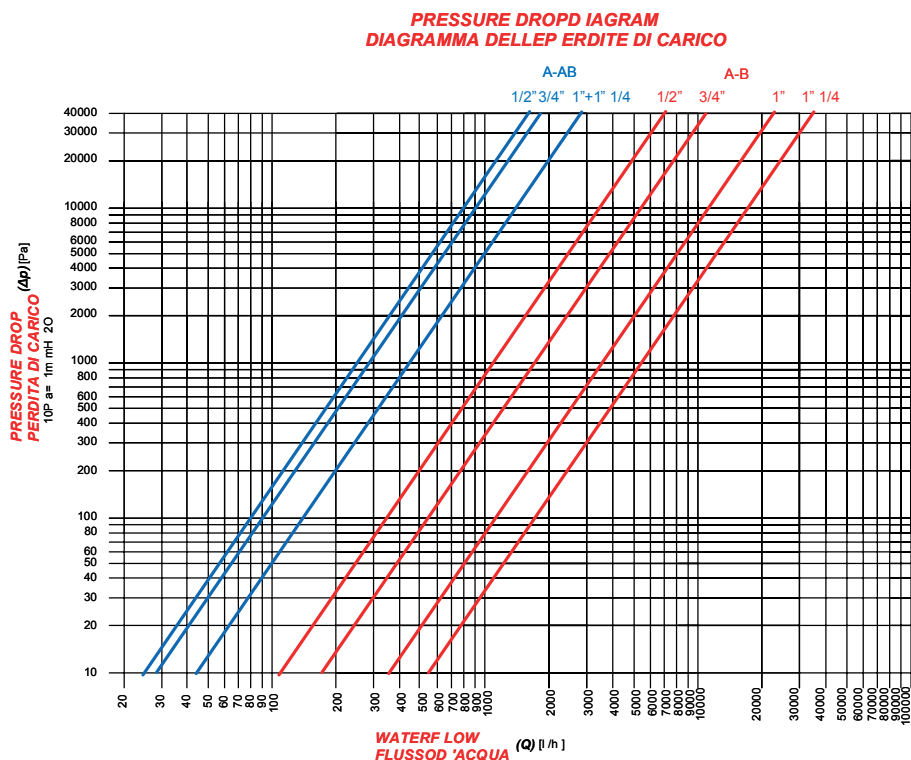

Size	Kv[[m³/h]
1/2"	10,82
3/4"	16,9
1"	33,9
1"1/4	55,36

Size	Kv[[m³/h]
1/2"	2,52
3/4"	2,86
1"	4,52
1"1/4	4,52

Art. 336-346 4 way zone ball valve

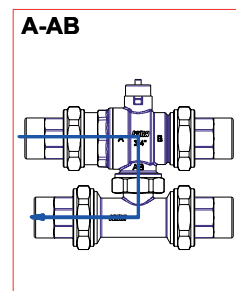
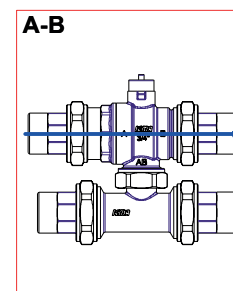
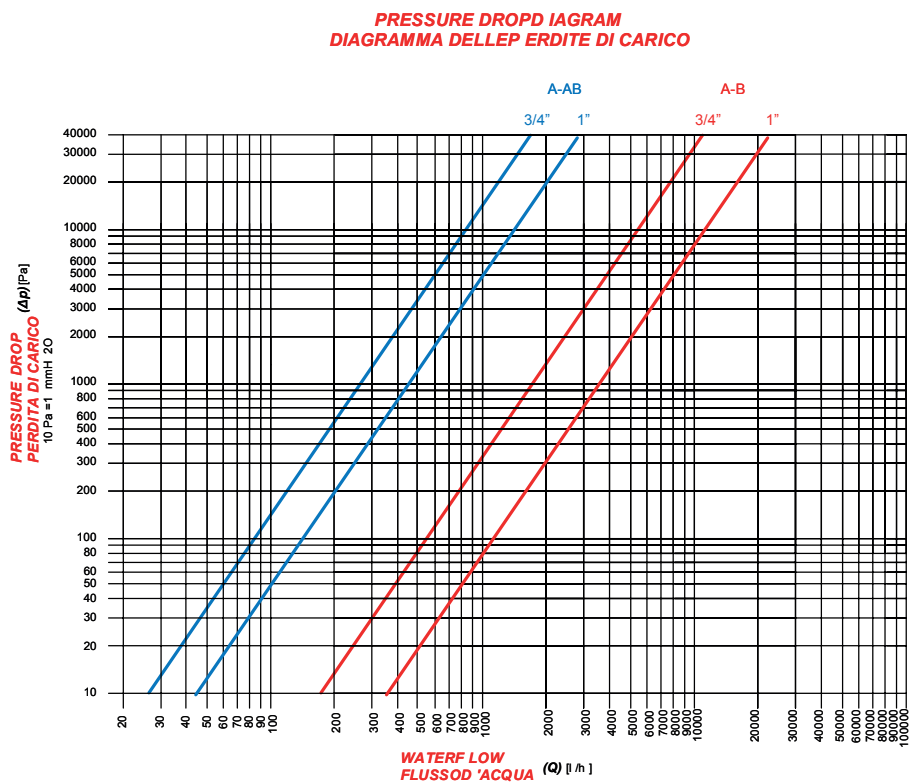

Size	Kv[[m³/h]
3/4"	16,9
1"	33,9

Size	Kv[[m³/h]
3/4"	2,64
1"	4,30

Installation with two-way zone valve

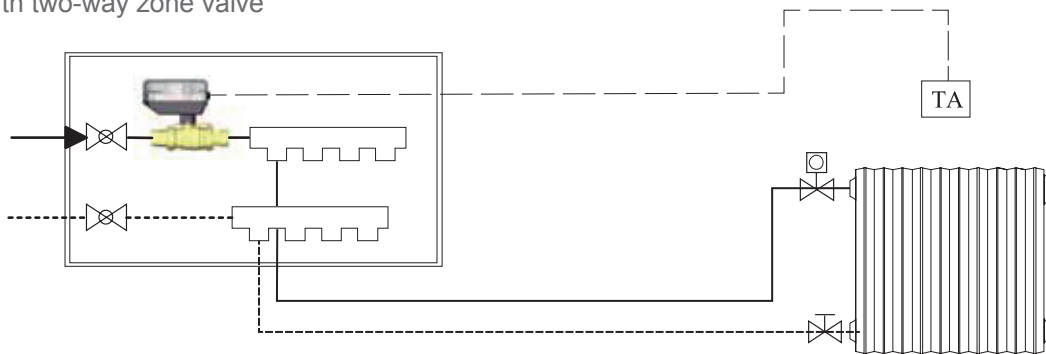

Installation with three-way zone valve, BY-PASS version

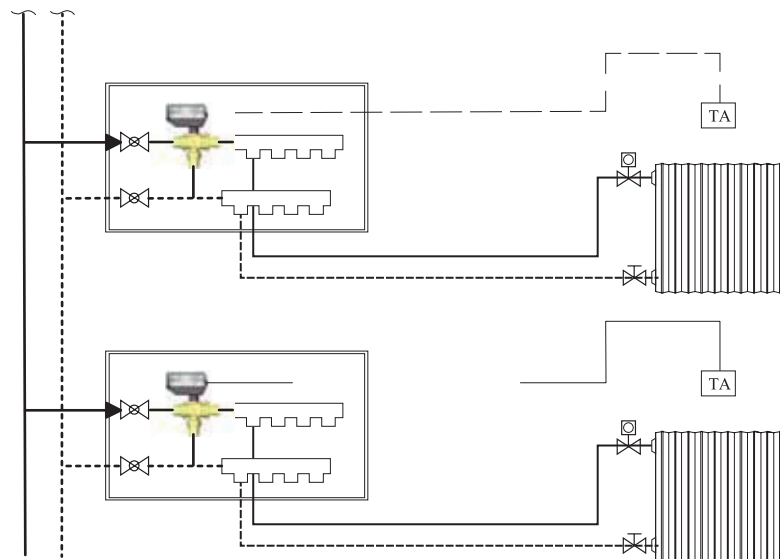

Installation with three-way valve, DIVERTING version

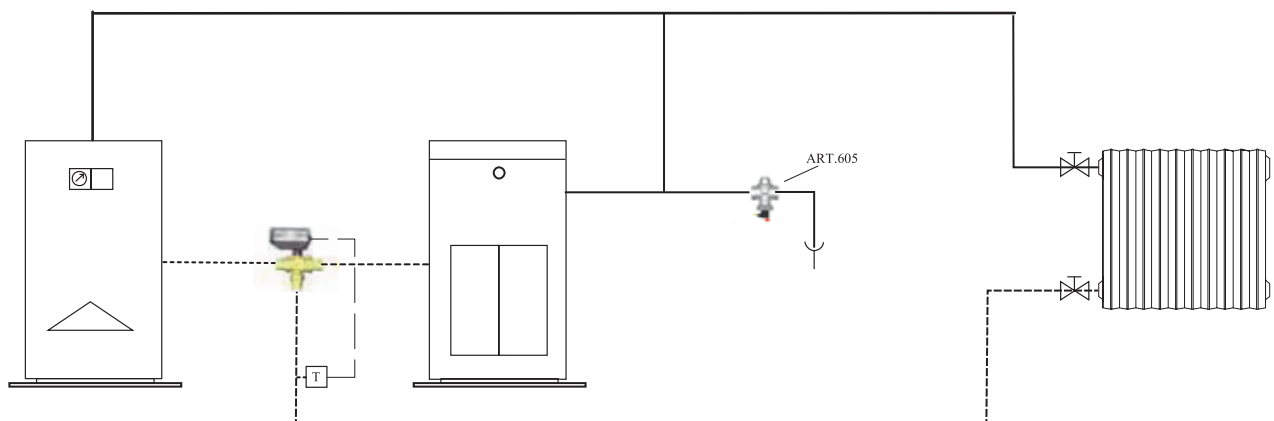

Installation with four-way zone valve

