

/ Description

Art. 740 deaerators continuously eliminate air from hydraulic circuits in climate control systems.

They eliminate all the air in the system, down to the level of microscopic bubbles, fully automatically.

ICMA deaerators guarantee optimal system operation without problems such as noise, corrosion, overheating or mechanical damage.



/ Products

Code	Size
82740AE05	G 3/4" F
82740AF05	G 1" F
82740AG05	G 1"1/4 F
82740AH05	G 1"1/2 F

/ Technical features

Body	Brass CW 617 N - UNI EN 12165
Cover	Brass CW 617 N - UNI EN 12165
Float	Polymethyl pentene
Internal element	Stainless steel
Floating guide	Brass UNI EN 12164 CW614N
Shutter rod	Brass UNI EN 12164 CW614N
Floating lever	Stainless steel
Spring	Stainless steel
Hydraulic seals	EPDM PEROX - (high resistance)
Fluids	water, glycolate solutions
Maximum glycol percentage	50%
Temperature range	-30° /160°C
Max operating pressure	10 bar
Max drain pressure	10 bar

/ Dimensions

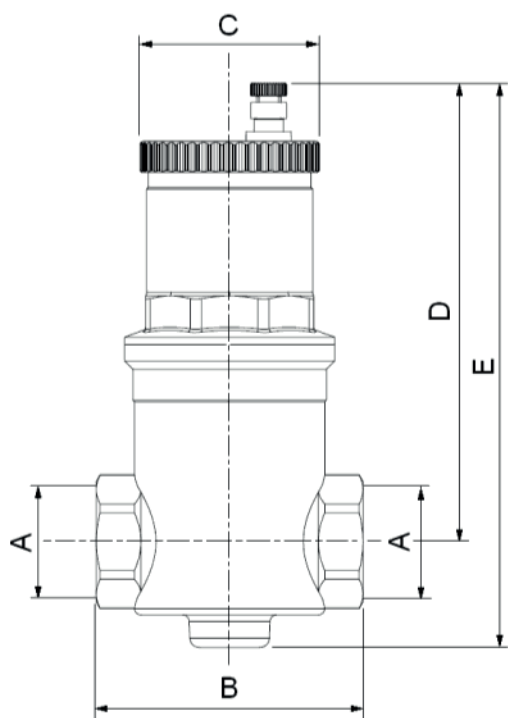

Code	A	B	C	D	E
82740AE05	¾"	82	55	141	173,5
82740AF05	1"	82	55	141	173,5
82740AG05	1"1/4	90	55	164,5	210,5
82740AH05	1"1/2	90	55	164,5	210,5

/ Installation

The deaerator should only be installed in the vertical position, preferably:

- upstream of the pump, where high fluid speed and the resulting pressure loss causes micro-bubbles to form more easily.
- on the return and the lower part of the solar circuit where there is no steam formation.

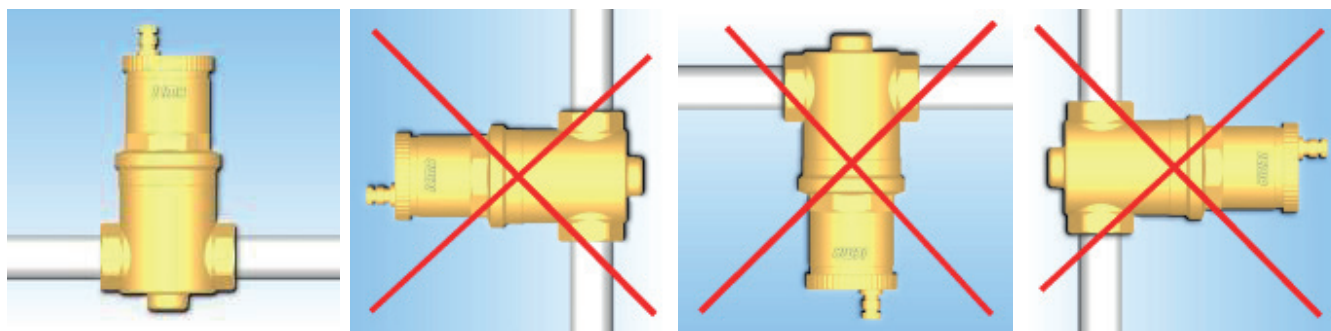

Application diagram

ICMA devices may be used on heating and cooling circuits to ensure progressive elimination of air. Installation is particularly recommended after the boiler, on the pump intake side, where microscopic bubbles are most likely to form (Fig. 4 on page 4).

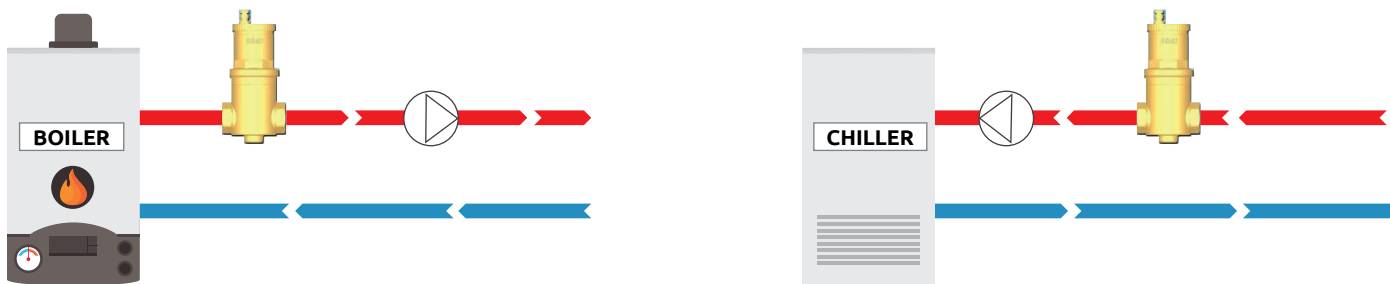

Operating principle

The deaerator works by the combined action of multiple physical principles. It contains a filtering mesh consisting of a series of radiating metal mesh surfaces (Part 1 in Fig.1).

These elements' adhesion to the surface creates motion which favours the formation and successive release of micro-bubbles.

Micro-bubbles come together and increase in volume. When hydrostatic thrust is sufficient to overcome the force of adhesion to the structure, they rise up toward the top of the device, from which they are then evacuated by an automatic air bleed valve with a float cock (Part 2 in Fig.1).

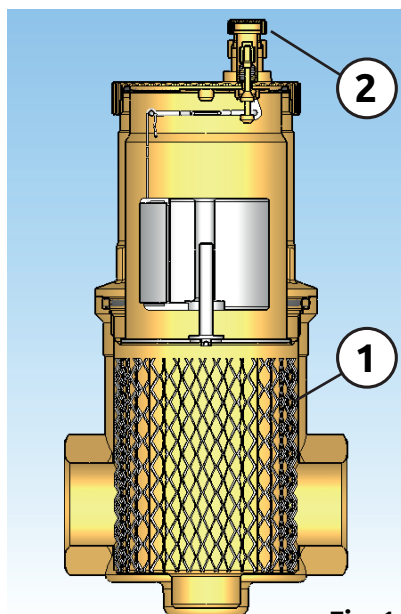

Fig. 1

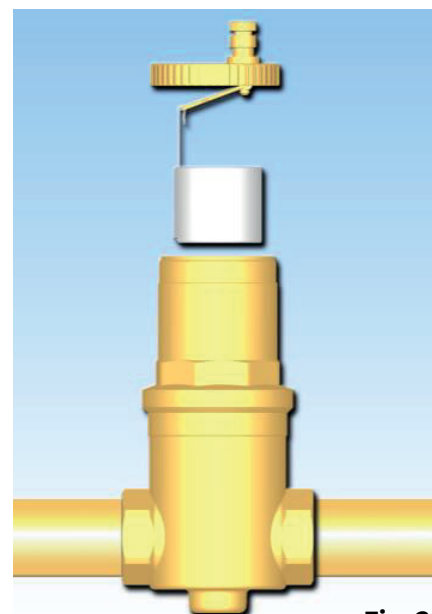

Fig. 2

Details of construction

ICMA deaerators are built to permit maintenance and cleaning without removing the valve body from the pipe. Moving parts commanding bleeding of air may be accessed by simply removing the top cover (Fig.2).

The filter mesh may be cleaned by simply unscrewing the top part of the body containing the automatic air bleed valve (Fig.3), .

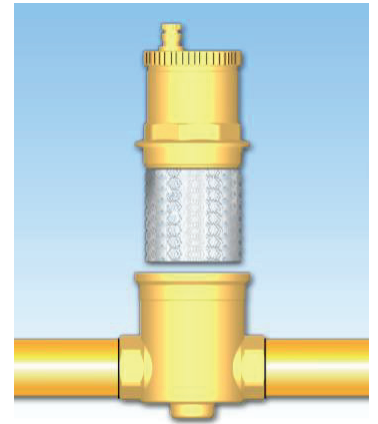

Fig. 3

Air bubble formation

The amount of air that can be dissolved in solution in water is determined by pressure and temperature. This correlation is regulated by Henry's law, which, as shown in the graph, allows us to quantify the physical phenomenon of release of air contained in fluid.

At certain temperature and pressure values, water tends to keep a corresponding amount of gas. In the event of an increase in temperature and/or a drop-in pressure, the gases released in the water will tend to increase. The opposite will occur in the event of cooling and/or a pressure increase.

This air takes the form of micro-bubbles with diameters in the order of a few tenths of a millimetre. Micro-bubbles form continuously in water in solar systems at the top of the panels, especially at the points in the circuit where the highest temperatures are reached.

This air is partly reabsorbed gradually as the fluid reaches parts of the circuit with lower temperatures, while part of it remains present in the fluid and must therefore be evacuated

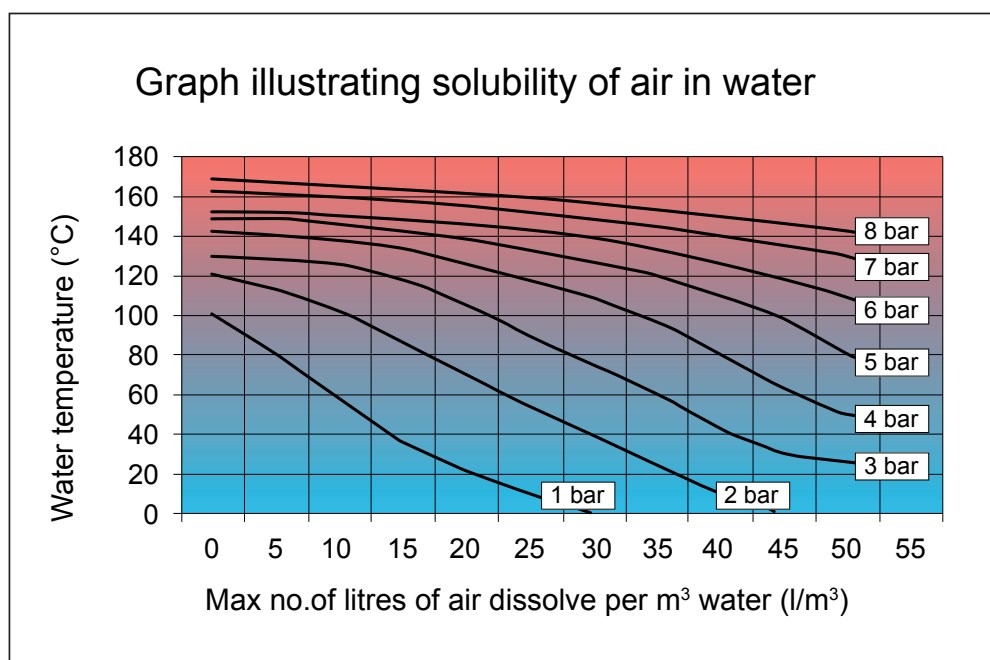

/ Micro-bubbles in the boiler

The picture illustrates the process of micro-bubbles formation in the boiler. Micro-bubbles are continuously formed due to the high temperature of the fluid. The gas thus generated is then carried by the water and will tend to collect at the most critical points in the circuit from which it must then be evacuated. Some of the micro-bubbles will be reabsorbed by the water near the coldest surfaces.

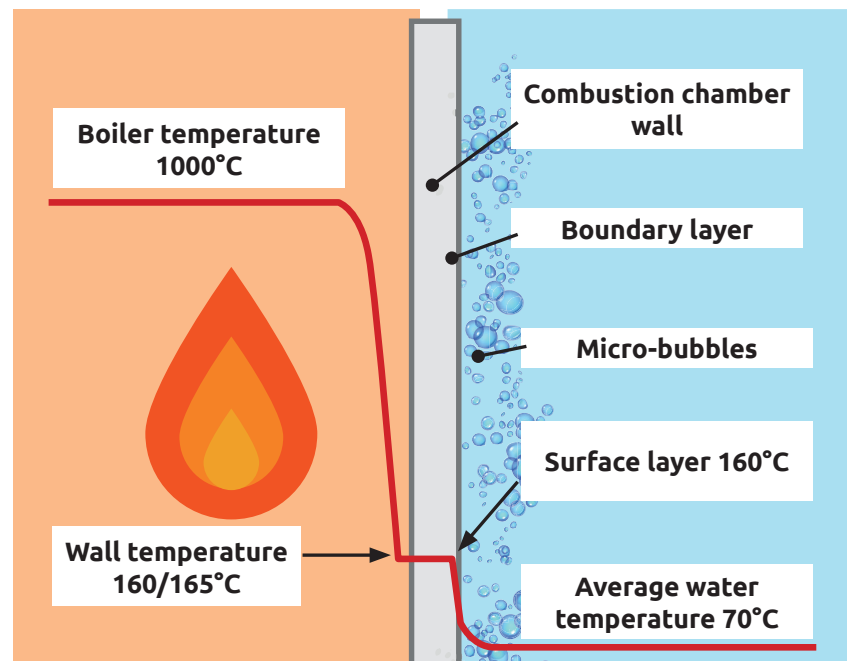

Fig. 4

/ Safety



To keep internal components in good condition, do not use cleaning products containing solvents. Read the assembly and start-up instructions and comply with them scrupulously before starting the system to prevent accidents and damage to the system caused by improper use. Remember that the guarantee will be forfeited in the event of any unauthorised changes or tampering with the device during assembly and construction. Comply with all safety warnings, and if you have any doubts about use or changes to parameters or functions, request the assistance of qualified service personnel